

www.catnic.com

Care has been taken to ensure that the contents of this publication are accurate, but Tata Steel Europe Limited and its subsidiaries, which includes Tata Steel UK Limited, do not accept responsibility or liability for errors or information that is found to be misleading. Suggestions for, or descriptions of, the end use or application of products or methods of working are for information only and Tata Steel Europe Limited and its subsidiaries accept no liability in respect thereof.

Before using products or services supplied or manufactured by Tata Steel Europe Limited and its subsidiaries, customers should satisfy themselves as to their suitability.

Catnic reserves the right to change information contained within this brochure at any time.

© Copyright 2016 Tata Steel UK Limited.

Catnic
Pontypandy Industrial Estate
Caerphilly
CF83 3GL
T: 029 2033 7900
F: 029 2086 7796
www.catnic.com



SSR² Standing Seam Roof & Cladding Product Guide

January 2016



Contents

- 4 Introduction
- 5 Materials and Finishes
- 6 SSR2 Roofing
 - Wind loading
 - Acoustics
 - Fire
 - Impact resistance
 - Condensation risk
 - Lightening risk
 - Standard Details
 - Installation Guidelines
- 13 SSR2 Wall Cladding
 - Wind loading
 - Acoustics
 - Fire
 - Standard Details Vertical Cladding
 - Standard Details Horizontal Cladding
 - Installation Guidelines
- 19 SSR2 Ancillaries
 - Soffits
 - Fascia
 - Gutters
 - Photovoltaic Fixing Brackets
 - Pipe Penetrations
- 21 Safe Storage and Handling
- 22 Catnic Service and Scheduling
- 23 Sustainability
- 24 Environmental
- 25 Case Studies



BUILD IT BETTER WITH CATNIC

SSR² standing seam roof and cladding is the latest innovation from Catnic.

A sustainable pre-finished steel roofing and cladding system designed for the residential and commercial market. SSR² is a fully supported standing seam system, designed, manufactured and CE Marked in accordance with BS EN 14783:2013.

SSR² is manufactured from Tata Steel's Colorcoat HPS200 Ultra[®] pre-finished steel, making it a cost effective alternative to traditional copper and zinc standing seam roof systems. Seven times lighter than clay or slate tile equivalents, it's easy to handle on site and quick to fix compared with traditional roofing products.

SSR² standing seam roof and wall cladding is lightweight, durable and easy to install. Available in a range of colours, the system provides an original and modern roofline for any property; for pitched roofs as low as 5°.

Our steel roofing and cladding systems are rated 'A+' within the BRE Green Guide, BBA approved and because it's Catnic you can rely on the best customer support and technical specification, to installation and beyond.

AN INTRODUCTION TO SSR²

An innovative steel system, creating imaginative finishes to a versatile range of unique projects across the UK.



Catnic SSR² has been exclusively designed to accommodate a wealth of building applications and installation requirements, from standard residential homes and executive dwellings, to social housing projects and community buildings.

Developed as an economic alternative to zinc, copper and lead, SSR² combines architectural aesthetic appeal and high performance.

Key benefits:

- Quick fit system reduces installation time on site compared with traditional roofing products
- Can be installed on a roof with a pitch as low as 5°
- Seven times lighter than traditional roof tiles
- When installed as wall cladding, can be laid vertically or horizontally
- Available with 305 mm or 514 mm cover widths
- BRE Green Guide A+ rated product and 100% recyclable at end of life
- BBA Approved Roofing & Cladding System, Certificate No: 15/5279
- Class AA (roof) and Class O (wall) Fire Performance rating
- Manufactured from Tata Steel's Colorcoat HPS200 Ultra® pre-finished steel which is certified to BES 6001 Responsible sourcing standard
- CE Marked to BS EN 14783:2013.

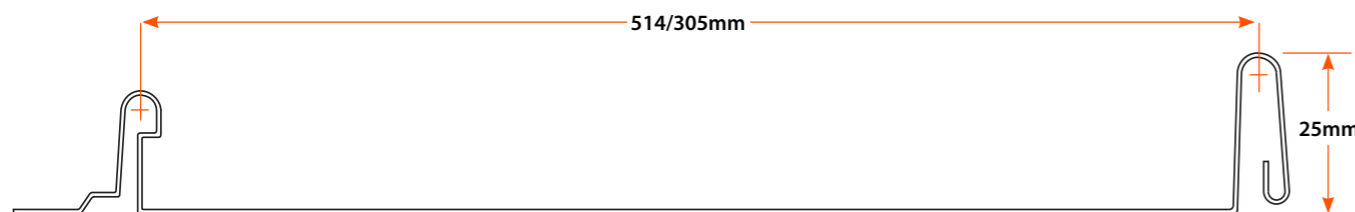

MATERIAL AND FINISHES

The quick fit roof and cladding system is manufactured from Colorcoat HPS200 Ultra®, which has been designed with leading architects to produce an enticing colour palette.

Made in the UK to European standards, the versatility of Catnic's latest product enables architects to design a variety of contemporary construction solutions that are lightweight and durable.

Colorcoat HPS200 Ultra® pre-finished steel by Tata Steel

Colorcoat HPS200 Ultra® pre-finished steel provides exceptional performance and corrosion resistance for building envelope applications.

It is backed up with even more extreme testing and real world global data to demonstrate the best combination of excellent colour stability, gloss retention and outstanding durability.

Whatever your type of building, from warehouses to houses, retail outlets to processing plants, Colorcoat HPS200 Ultra® demonstrates proven performance and reliability.

Product features and benefits:

- Optimised Galvalloy® metallic coating for exceptional corrosion resistance and cut edge protection.
- Surpasses requirements of Ruv4 and RC5 as per EN 10169:2010 proving excellent colour and gloss retention and corrosion resistance.
- Scintilla® embossed as a mark of authenticity from Tata Steel.
- Made in the UK for a lower carbon footprint and certified to BES 6001 Responsible Sourcing standard.
- BBA certified for durability in excess of 40 years.
- Fully recyclable.

Scintilla®

Unique to Colorcoat HPS200 Ultra® the Scintilla® emboss has been developed with a depth of only nominal 50 microns, which makes it less likely to trap dirt than deeper leathergrain embosses therefore making the pre-finished steel easier to clean whilst being more robust.

Unlike leathergrain patterns the emboss is subtle and does not detract from the overall appearance of the building, looking smooth and creating a modern building appearance from a distance. The Scintilla® emboss provides a unique guarantee of authenticity and an overall thicker protective top coat from Tata Steel.

British Board of Agrément Certificate

The long-term performance of Colorcoat HPS200 Ultra® has been recognised within BBA certificate 91/2717 as "Colorcoat HPS200 Ultra® coating and metal treatment will protect the steel substrate against corrosion for a period in excess of 40 years in normal industrial, urban, suburban and rural environments."

Colorcoat, Colorcoat HPS200 Ultra, Galvalloy and Scintilla are trademarks of Tata Steel UK Limited.

Colour excellence

Excellent colour and gloss retention to the highest European standards, enable your roof to retain its colour for longer, with Galvalloy® metallic coating for ultimate corrosion resistance.

Colour guide

A naturally inspired blend that is sympathetic to the urban landscape, ensuring harmonious integration with the surrounding environment. The tonal matt shades integrate seamlessly between different facades including glass, brick, wood, stone and render delivering effortless modern finishes.



RAL References

4 digit numbers are RAL Classic references. 7 digit numbers are RAL Design references. RAL reference numbers shown, represent the nearest colours and are not exact matches to Colorcoat HPS200 Ultra®.

Colour consistency

If tonal consistency is critical, all cladding for a single elevation should come from the same production batch.

Matching components

If accessories made from other materials are to be colour-matched to the roof or wall cladding, the best reference is the actual profiles or panels delivered to site, or material from the same batch.



Colour swatch samples are available on request please contact catnic.marketing@tatasteel.com or call

+44 (0) 2920 337919

SSR² ROOFING

For conventional structure and housing design, SSR² offers the traditional formed standing seam profile, an ideal choice for low rise and residential solutions.

Performance details

Wind loadings on a roof are dependent on:

- Building location
- Building height and number of storeys
- Roof pitch
- Topography

SSR² has been designed to withstand wind loadings across the UK as calculated in accordance with BS6339-2 and BS EN 1991-4. The table below gives guidance on the suitability and specification of SSR² roofing panels for different buildings.

Roof Pitch	No. of Storeys	Wind Speed V_s	305mm Panel Width	514mm Panel Width
5-9°	<3	<25	✓	✓
		≥25	✓	X
5-9°	4-8	<25	✓	X
		≥25	✓	X
≥10°	<3	<25	✓	✓
		≥25	✓	✓
	4-8	<25	✓	✓
		≥25	✓	X

A structural engineer should complete a wind uplift calculation for your specific location before making any final decisions.

The SSR² standing seam roof can be fixed to 18mm OSB 3, WBP and marine ply board or SIP panels with a 15 mm boards. The characteristic pull out resistance of the fasteners used to fix SSR² are shown in the table opposite.

UK Wind Chart

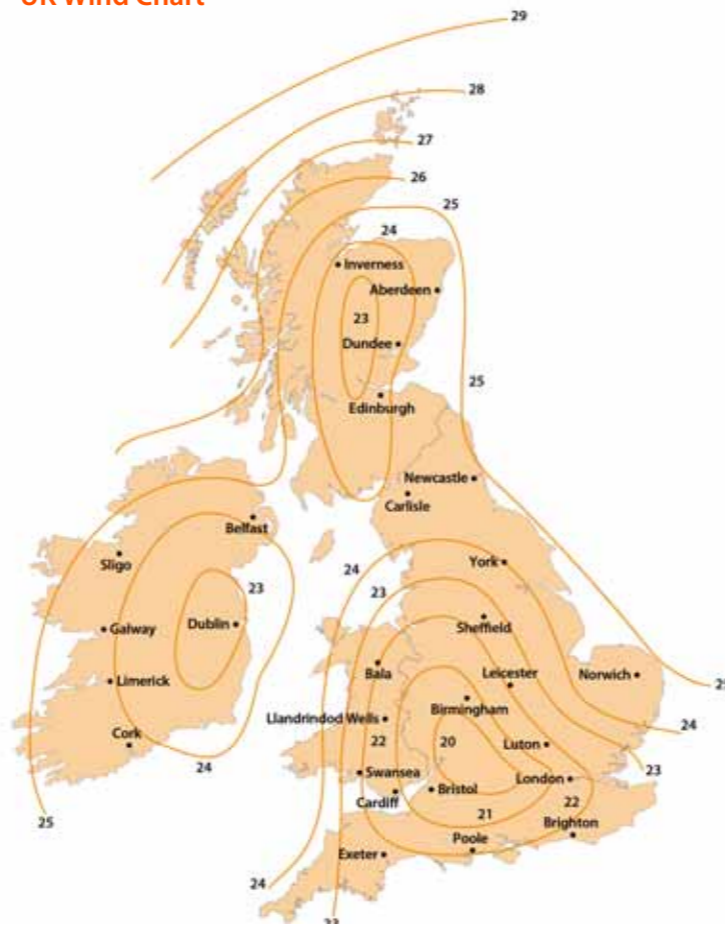

Fixing Type	Thickness of OSB Board (mm)	Characteristics Resistance (kN)
Z-FRP40W3	15	0.88
	18	1.10

SSR² ROOFING

Acoustic

The built up nature of SSR² standing seam roof and cladding allows greater flexibility to deliver acoustic solutions for residential and commercial buildings.

The structure of a building's walls and roof can be engineered to modify the level of sound energy according to the client's acoustic requirements. Where special considerations are essential, architects / specifiers will address the needs to control the internal acoustics or reverberation of a building with input from an acoustic engineer.

In very high winds "drumming" of the SSR² could occur. To minimise any possibility of this occurring the mid-span deflection of the sheet should be limited to 10mm. The table below shows the maximum allowable wind uplift to limit deflection to 10mm and 20mm.

Uplift wind deflection values (kN/m²)

	10mm deflection	20mm deflection
305mm	3.49	6.98
514mm	0.73	1.46

Impact resistance

SSR² standing seam panels used in both roof and cladding applications, will have adequate resistance against hard and soft body impact in combination with the standard wood board build up. Panels have been engineered for impact resistance in accordance with MOAT 43: UEATc Directives for impact testing opaque vertical building components, and Part 2.2.1: Impact from large soft bodies and MOAT 43: UEATc Directives for impact testing opaque vertical building components. Part 2.2.2: Hard body impacts.

Condensation risk

All roof systems are prone to the risk of condensation; this can arise as either interstitial condensation within the roof construction or surface condensation at areas of thermal bridges.

Simple measures can be taken to prevent condensation forming between the panels and underlying substrate, thus minimising the risk of water vapour reaching the OSB board:

- Vapour control layer in the roof construction providing an adequate seal around the ceiling to prevent moisture entering the roof construction.
- Breather membrane in the roof construction to allow the air to circulate freely
- Adequate insulation level meeting current U-values

Fire

Catnic's SSR² manufactured from Colorcoat HPS200 Ultra® can meet all the fire performance requirements for external roof coverings.

Colorcoat HPS200 Ultra® has a notional designation of AA (National Classification) and BROOF(T4). There are no restrictions in UK Building Regulations on the use of roof coverings that are designated AA, AB or AC or BROOF.

*Terms and conditions apply

European roof products that meet the requirements stipulated in Commission Decision 2000/533/EC can be considered to satisfy the requirements without the need for testing.

Lightning risk

The Catnic SSR² standing seam roof is no more likely to be struck by lightning than any other roofing material; it is the building shape and position relative to other buildings that has most influence over a lightning strike. Metal roofs are generally safer than other roofs in a lightning storm.

There is no specific requirement for the Catnic SSR² standing seam roof to have a lightning conductor but as with most buildings any risk of lightning striking the building should be covered during the design of the building by a suitably qualified person. The risk assessment would normally be carried out in line BS EN 62305.

SSR² ROOFING

The versatility of SSR² standing roof system allows for a variety of construction solutions.

Warm roof build - up

SSR² standing seam warm roof system encompasses the essentials of modern metal roofing. The metal profile provides the traditional pitched detailing of a standard roof, whilst the inherent thermal performance is provided by standard insulation in a tightly packed formation.

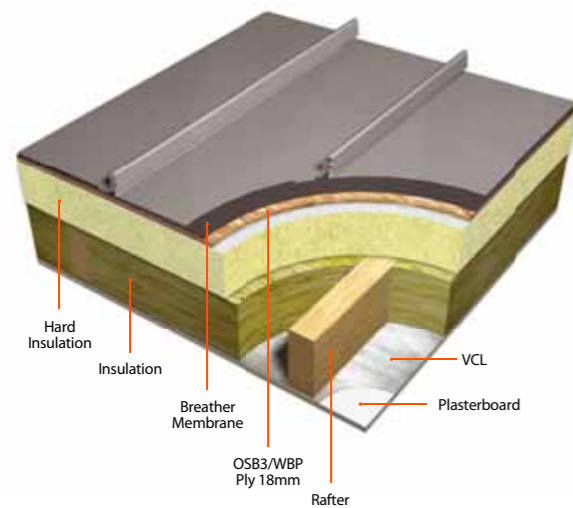

Cold roof build - up

SSR² standing seam cold roof system contains all the details of a warm roof system, but has been specifically designed for use on pitched roofs, and is suitable for use within the majority of timber framed construction. Allowing an additional 50mm air cavity and optional VCL to increase air tightness, whilst introducing a foam pad insulation instead of the hard insulation incorporated into the warm roof build-up.

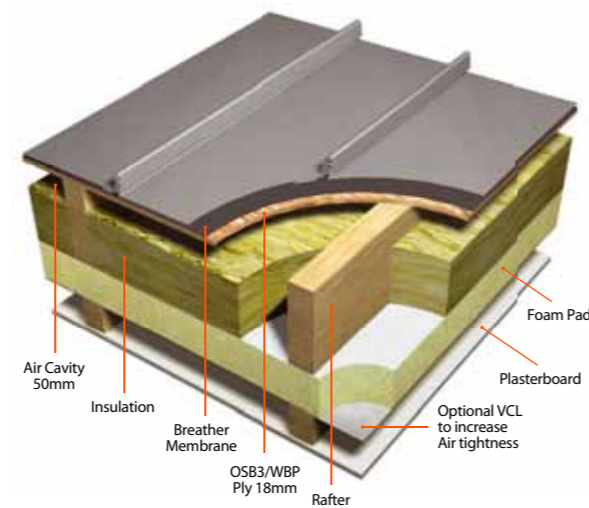

Simple locking design



SSR² ROOFING

Duo Pitch Ridge

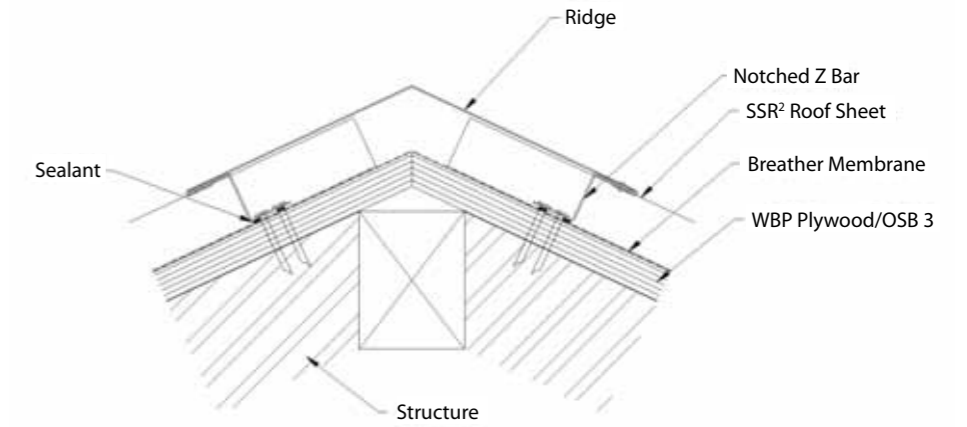

Mono Ridge

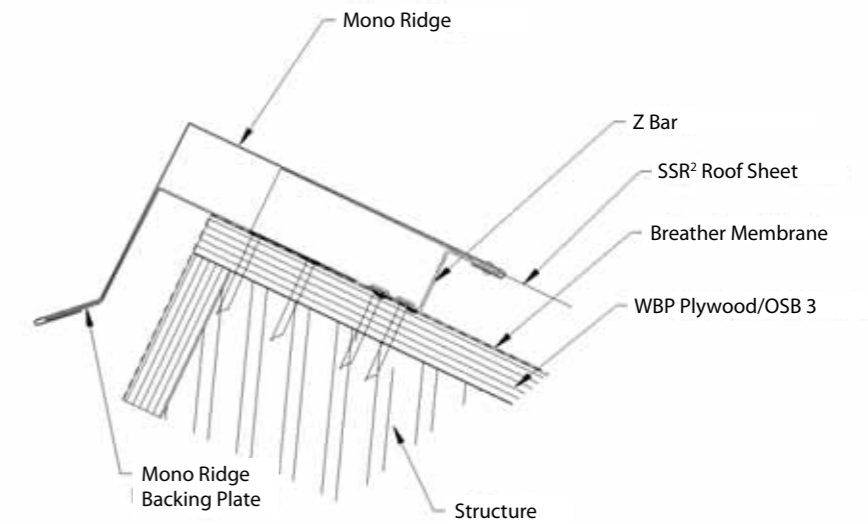

Top Abutment

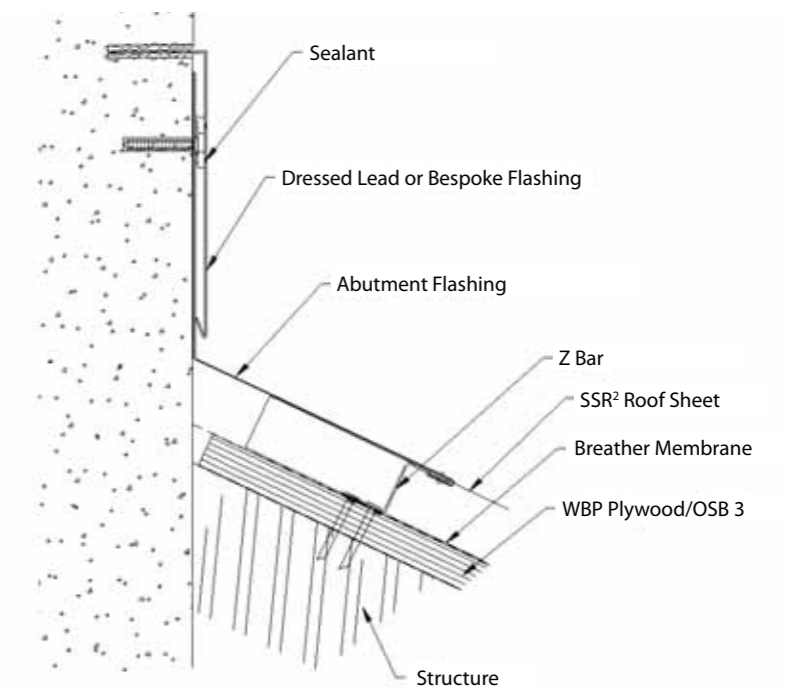

SSR² ROOFING

Eaves

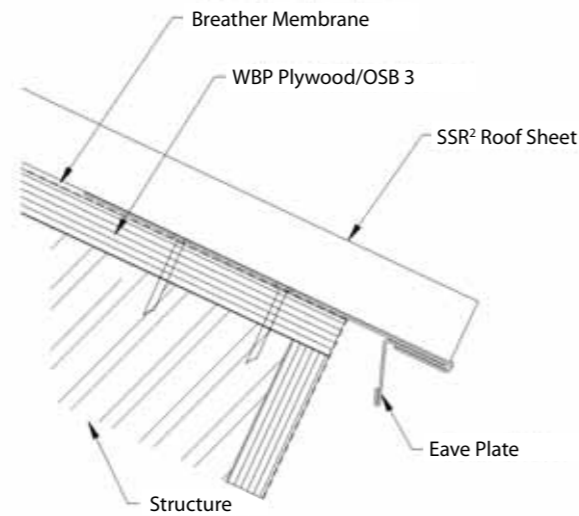

Verge

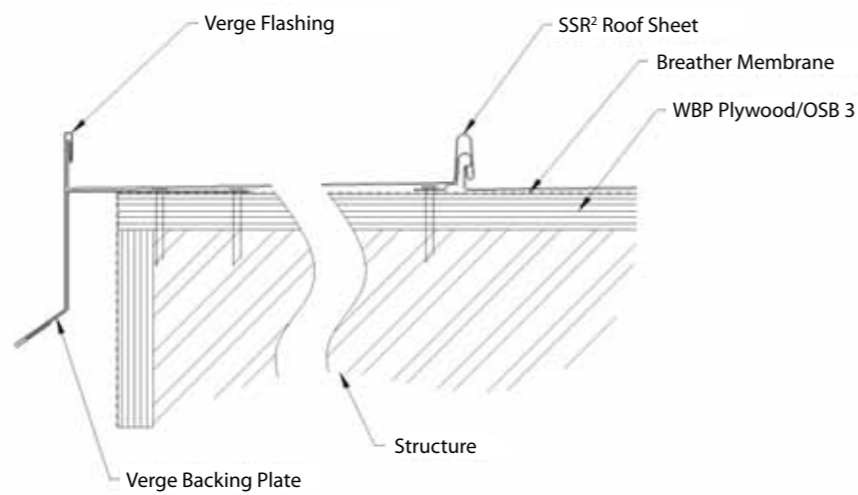

Side Abutment

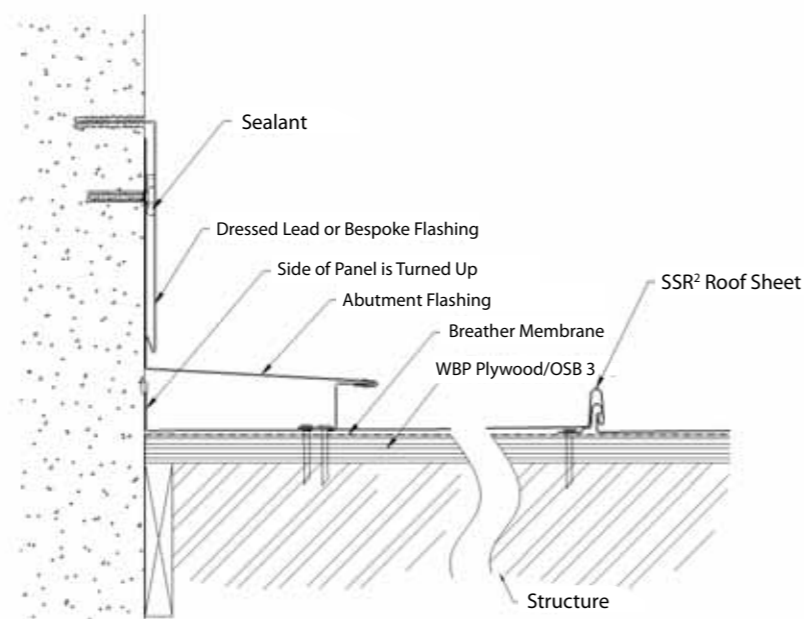

SSR² ROOFING



Installation guidance

Comprehensive installation and specification guides are available from Catnic on request. For those unfamiliar with metal roofing systems we have outlined the basic procedures and processes.

Measuring a Roof

Catnic manufactures all roof and wall components based on accurate measurements supplied by the customer. These details should be provided within the drawings produced by the roof truss or SIP panel manufacturer.

Please read this document carefully before specification and ordering

The maximum panel length produced by Catnic is 12.5m, this is due to the thermal expansion of the panel. When installing roofs over 12.5m we recommend panels are split or a change in the fall created with a mansard or two joining panels.

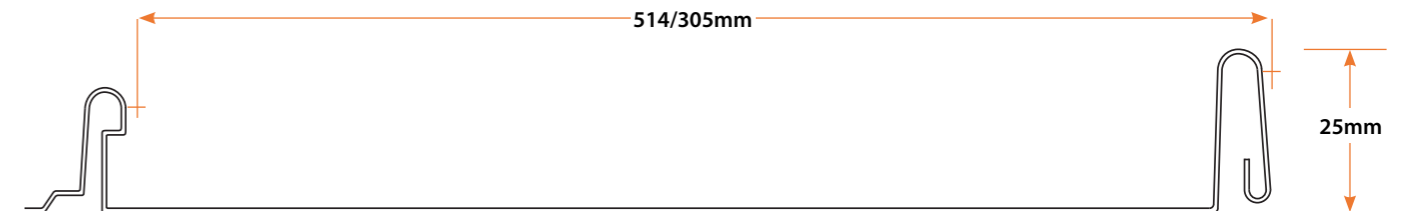

When estimating please remember:

For straight roofs we require the following details:

- (L) rafter length including fascia board
- (R) angle of pitch
- (a) identify whether mono or duo pitch roof is required

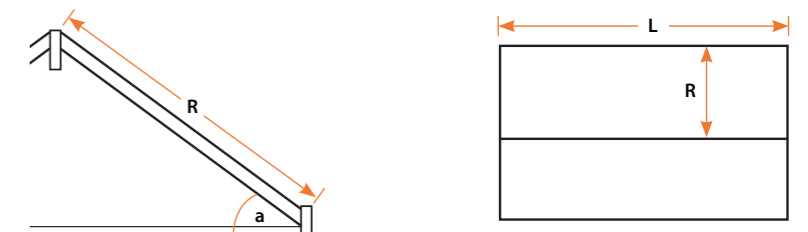

When estimating fixings please note the 514mm wide panel will require a minimum of 6 fixings per square metre, and four fixings per linear metre along the eaves and verges. At the ridge 8 fixings per linear metre

is required for duo pitched roofs and 4 fixings for mono pitched roofs. If using screws for the ridge, remember to space every 500mm, halving the number of ridge fixings.

IMPORTANT NOTICE

Whilst Catnic take care in providing information or advice on its products, we do so only on the basis of the facts that may be supplied (and without further investigation of them) and do not accept any responsibility for providing inaccurate, misleading or incomplete information or advice.

Before relying on any information or advice supplied by Catnic (whether in this communication or otherwise), the recipient should satisfy itself of the accuracy and appropriateness of that information or advice.

SSR² ROOFING

SSR² Installation

Existing Controls:

1. Cut resistant gloves to be worn when handling SSR² steel components.
2. Two man lift when lifting & positioning panels
– Refer to risk assessment for lifting procedure.
3. Working At Height – Fall arrest mats to be positioned at perimeter of training rig.
4. PPE - As per risk assessment.
5. Work area to be segregated by temporary safety barrier / bunting.
6. Contractors to be supervised when operating nailing equipment.
7. All lifting activities to be communicated to training supervisor.
8. Only training supervisor to operate circular saw.

Operation: Installation of SSR²

Roof Panels

1. Refer to the roof drawing to ensure the roof dimensions provided correspond to, panel lengths and quantity of panels including starter and end panel widths. (When calculating the roof cover width, an additional 25mm are added for an overhang at both start & end positions) mark the panel seam positions across the width of the roof to check the cover width is correct.
2. Check the boarding surface for any protruding screws, nails or staples. If found remove before installing panels.
3. Identify the starter panel, this has an upturned flange and nailing strip.
Note - Both starter and end panels will require 25mm notches cutting.

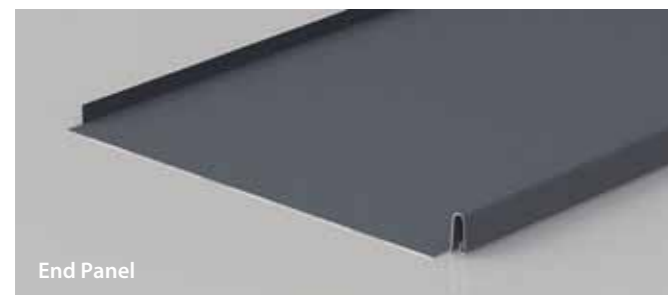
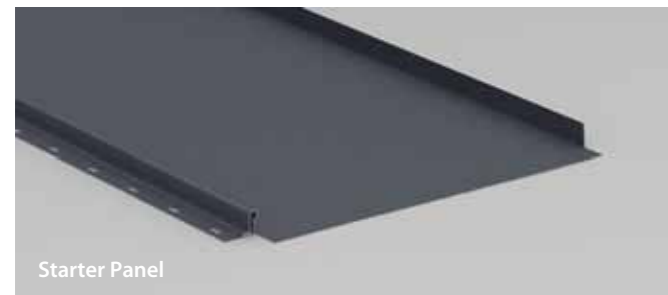

4. Lay the panel on the roof with the notched end positioned to the eave. Allow the end of the pan up to the notch to fall over the eave, using the flange mate, fold the pan down past 90 degrees so as it latches under the eaves plate. When installing in hot conditions position the panel notch slightly forward of the eave plate (Approx 3-4mm) and fit fasteners into the back third portion of the nailing slot. On very cold days position the panels so the notch is located level to the eave plate and the fasteners installed into the front third portion of the nailing slot. The installer should also ensure that the cover width is maintained.
5. Locate the starter panel so as the flange/upturn is positioned level to the outside edge of the verge backing plate.
6. Fasten the starter panel in position using the specified nails. All fasteners should be installed into the nailing strip slots at 180mm centres. Nails must be installed to allow lateral movement during expansion and contraction.
7. Once the starter panel is secured all intermediate panels can be installed. Follow steps 4 & 6. Position the folded notch to the eave plate and align the female profile over the male of the previously installed panel. Using a rubber mallet hammer the female profile onto the male.
8. Once the male and female seams have been connected the panel can be secured as per step 6. The installer should also ensure that the cover width is maintained. The panels may need stretching to ensure the cover width of 514mm or 305mm is maintained. This is achieved by pulling the pan against the clipped edge before fastening.
9. Once the panels are secured to the roof substrate, the end of the pan can be formed around the eave plate with a rubber mallet. The end of the pan can then be fully formed to the eave plate using the eaves closer.
10. Where an end panel has not ordered this easily be made on site from a standard SSR² Roof panel.
11. Before fitting the end panel, the remaining verge backing plate must be installed to compensate for any minor discrepancies in the cover width and end panel width.
12. Follow steps 2, 3, and 4 when fitting the end panel. The end panel will not require any fasteners as it is secured using the male profile of the previously installed panel and verge plate.
13. Once all roof panels have been fitted the appropriate ridge or apron detail can be fitted using the notched Z bars.

Installation training - Full training for all installers is available free of charge, and recommended for anyone using this product for the first time. Email catnic.marketing@tatasteel.com to register your interest today.

SSR² WALL CLADDING

For conventional structure and housing design, SSR² offers the traditional formed standing seam profile, an ideal choice for low rise and residential solutions. SSR² cladding panels can be installed vertically, horizontally or even diagonally to provide the desired appearance.

Performance details

Wind loading

SSR² has been manufactured to meet all the necessary legislative requirements, including wind loading in accordance with EN 1991-4.

Acoustic

The main considerations when looking at acoustic performance are sound reduction and sound absorption.

Sound reduction is a measure of the reduction in sound level of noise escaping from a building or entering a building from an external noise source such as traffic etc. In traditional construction, the sound reduction is proportional to the mass but in metal cladding systems it is also improved by use of airtight skins combined with soft acoustically absorbent insulation and air spaces.

Sound absorption is the damping of echoes or reverberant sound that would normally reflect back off internal surfaces. Different internal lining will affect the sound absorption of a room.

Figure 2. Acoustic performance factors

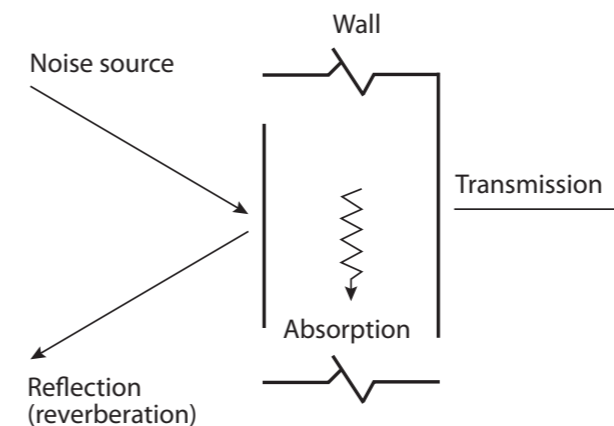

The structure used to support the SSR² cladding can be designed specifically to provide walls with the required acoustic performance.

Fire

Approved Document B specifies the performance requirements for the external surface of walls according to building height and location. Cladding systems using Colorcoat HPS200 Ultra® achieve Class O under UK Building Regulations and therefore meet all the fire performance requirements for the external surfaces of walls.

To achieve Class O a product must have:

- Fire propagation indices $I_s \leq 12$ and $i_1 \leq 6$ when tested to BS 476 Part 6.
- A Class 1 for surface spread of flame when tested to BS 476 Part 7.



SSR² WALL CLADDING

Vertical Cladding Details

Cill Detail

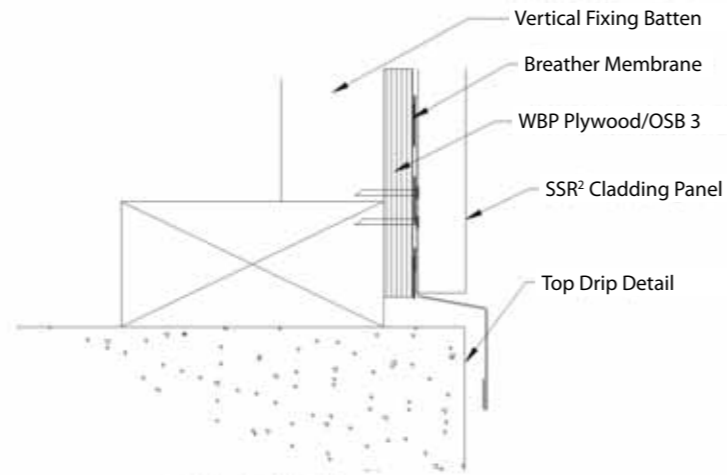

External Corner

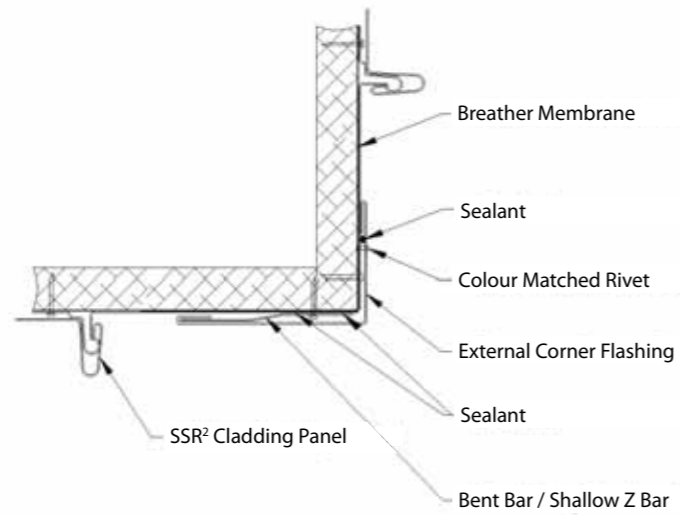

Window Head

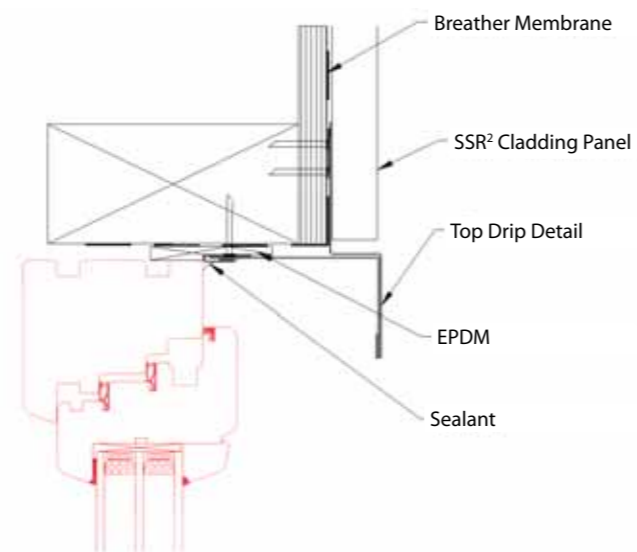

SSR² WALL CLADDING

Vertical Cladding Details

Window Jamb

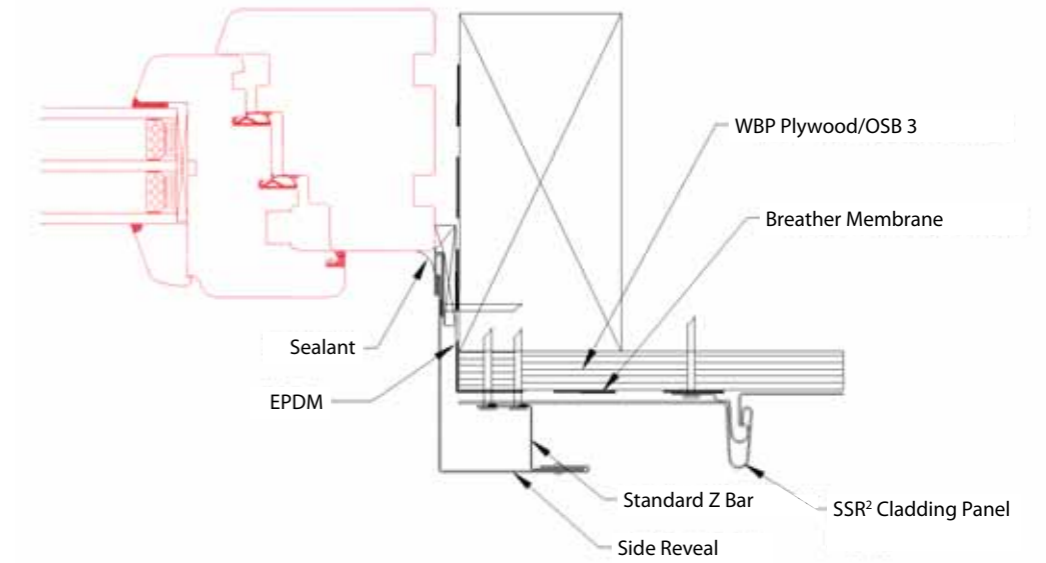

Window Cill

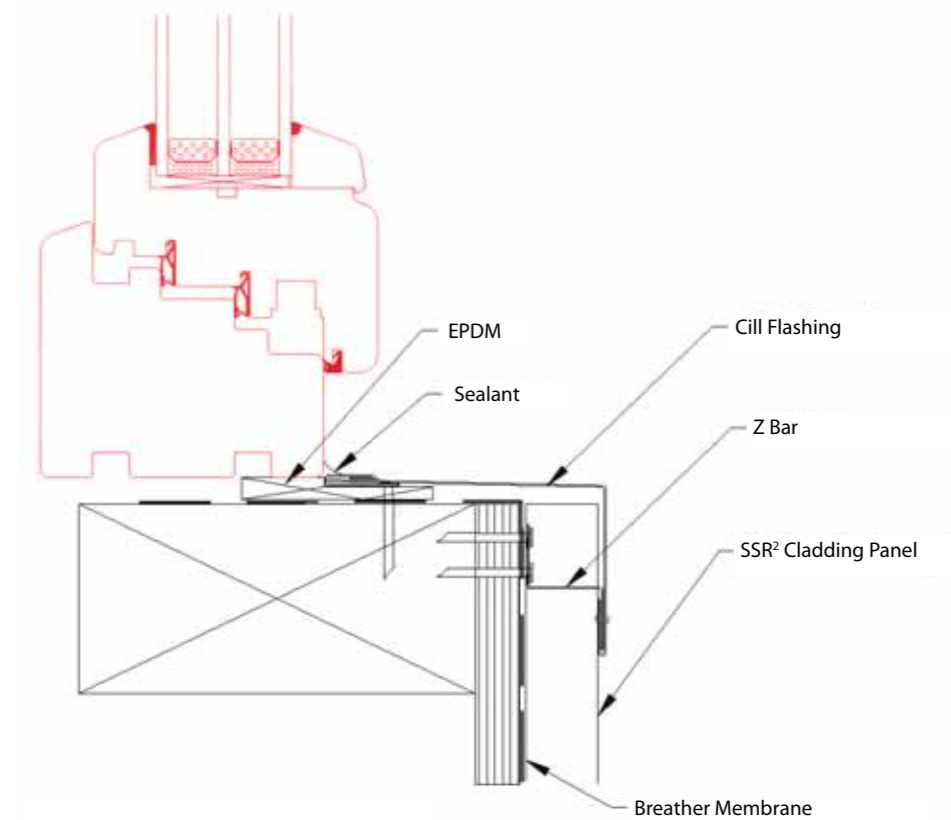

SSR² WALL CLADDING

Horizontal Cladding Details

Cill Detail

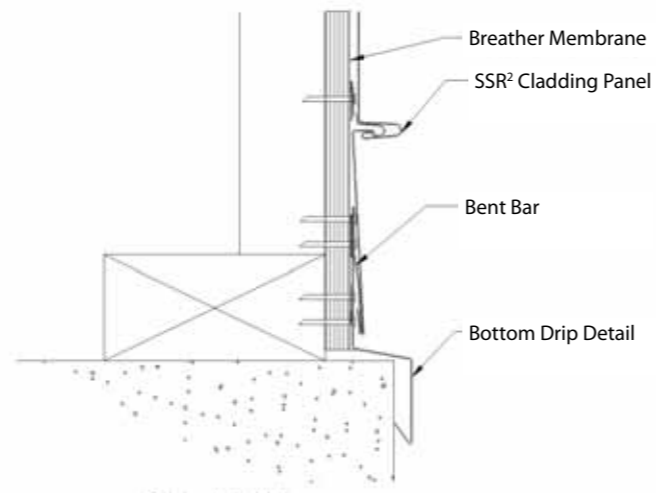

External Corner

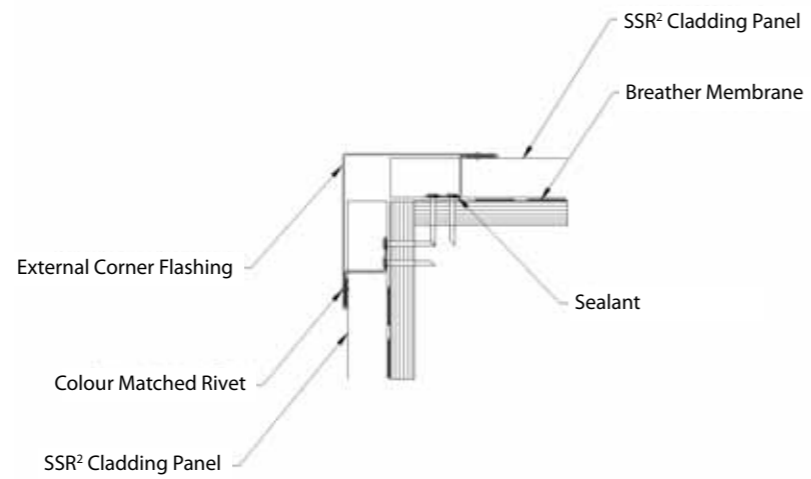

Window Head

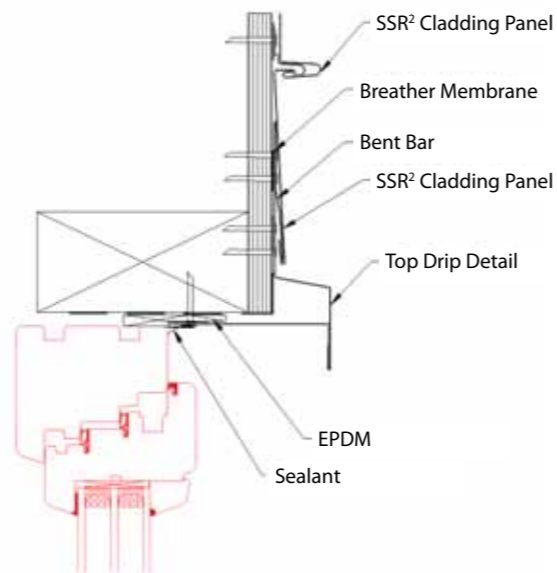

SSR² WALL CLADDING

Horizontal Cladding Details

Window Jamb

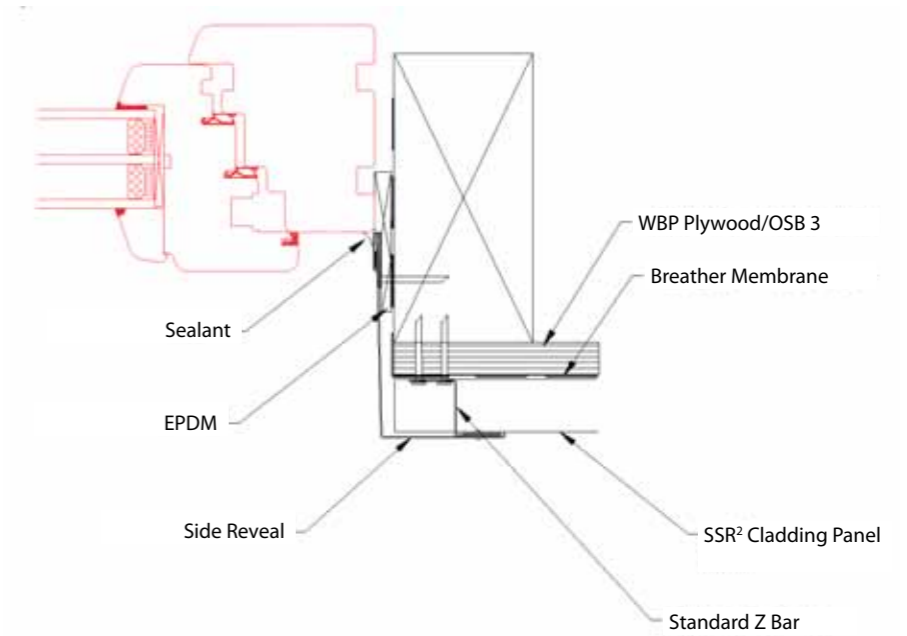

Window Cill

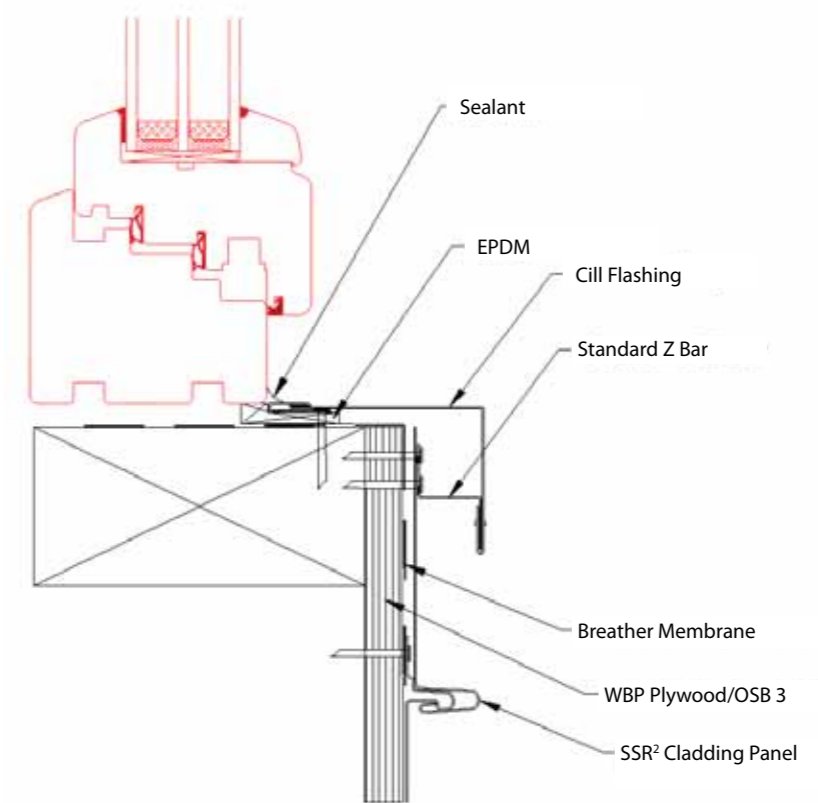

SSR² WALL CLADDING

Installation basics

Comprehensive installation and specification guides are available from Catnic on request. For those unfamiliar with SSR² systems we have outlined the basic procedures and processes.

Installation of SSR² Vertical Wall Panels

1. Refer to the wall drawing to ensure the dimensions provided correspond to, panel lengths and panel cover width including starter and end panels. Mark the panel seam positions across the width of the wall to check the cover width is correct.
2. Identify the direction of lay and check that the panel seams do not clash with any detailing around window apertures. Adjust the starter location as required.
3. Fit the Bottom drip or eave plate dependant on specification. The eave plate or drip must be secured to the 18mm board at 200mm centres.
4. Turn the starter panel face down, using the flange mate, form the end of the pan into an open welt. If the panel is to sit above a drip, form the welt closed as much as possible.
5. Position the panel against the wall with the bottom edge located approximately 10mm above the drip. If the panel is to be installed onto an eave plate, feed the leading edge of the eave plate into the open welt. Using a level check the panel is square and fit a single fastener at the top of the nailing strip.
6. All remaining fasteners must be fitted into the nailing strip at 180mm centres. All fasteners must be fit to allow lateral movement during expansion and contraction. When installing in hot conditions fit fasteners into the top third portion of the nailing slot. On very cold days the fasteners should be installed into the bottom third of the nailing slot. The installer should also ensure that the cover width is maintained.
7. Once the starter panel is secured all intermediate panels can be installed. Follow steps 4 & 6.
8. Internal & External corner angles are secured using bent bars & rivets located at 200mm centres.
9. If installing panels above a drip, align the female profile over the male with the seam level at the bottom. Using a rubber mallet hammer the female profile onto the male. (Bottom to top).
10. If installing panels onto an eave plate, feed the leading edge of the eave plate into the open welt. Using a rubber mallet, hammer the bottom 100mm of the seams together. Check the seams are aligned at the bottom, if not, use a timber lever to lift the female seam up into the correct position. Hammer the seams together. (Join seams in single direction. Bottom to Top).
11. When cutting panels to install around window apertures please refer to specific installation guidance from Catnic.

Please see Catnic for specific installation guidelines for horizontally laid SSR² Cladding panels.



SSR² ANCILLARIES

To complete the SSR² roofing and cladding system Catnic offer a range of ancillaries:

- Soffit panels
- Fascias
- Gutters
- PV fixings
- Pipe penetration details

Soffits

Secret fix soffit panels, manufactured from Colorcoat HPS200 Ultra® are available in the same range of colours as the SSR² roofing and cladding panels. They provide a simple, lightweight and durable finish to the underside of overhanging eaves, verges and mono ridges.

Fascia

Colorcoat HPS200 Ultra® Fascia sections are available in a range of sizes that can be fixed over the timber barge & fascia boards. As well as continuing the appearance of the roof over on the fascias, they also provide a very low maintenance protective finish.

Gutters

Catnic offer a standard box gutter to match the SSR² roof. This is available with a full range of ancillaries such as:

- Down pipes
- Swan necks
- Hoppers
- Stop ends
- Corners

As well as a standard box gutter Catnic can also design and manufacture bespoke gutters, typically required for valleys, parapet and hidden gutter situations. Manufactured from Colorcoat Aquatite® and supplied with all the necessary ancillaries.

Photovoltaic Fixing Brackets

With the increasing popularity of photovoltaic roof panels, Catnic can provide a simple fixing bracket that simply screws to the standing seam upstand. The allows photovoltaic panels to be installed without needing to put holes through the roof, maintaining the integrity of the roof and reducing installation times.

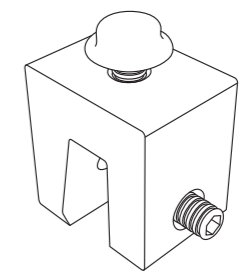

Pipe Penetration

While penetrations in a roof should be avoided where possible, they are an inevitable requirement. Catnic offer a range of standard flashing kits for square penetrations and range of flue penetration gaskets for round pipes including wood burning stove chimneys.

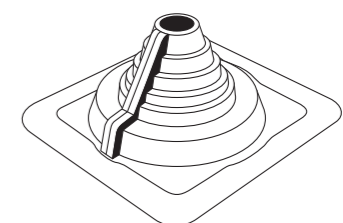

SSR² ANCILLARIES

Typical Soffit, Fascia and Gutter Details

Overhanging Eaves with Box Gutter

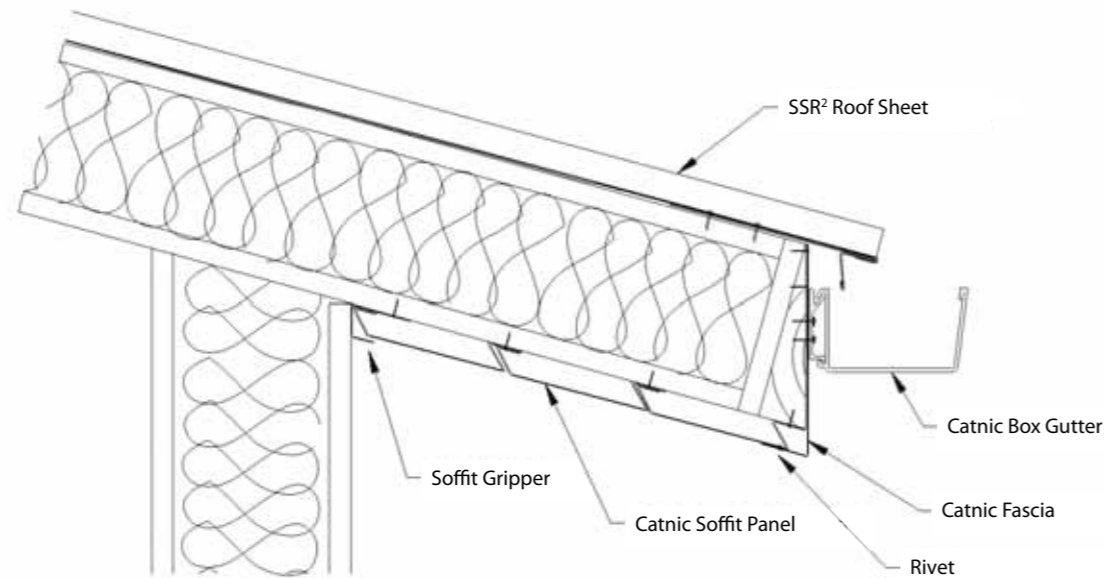

Internal Gutter

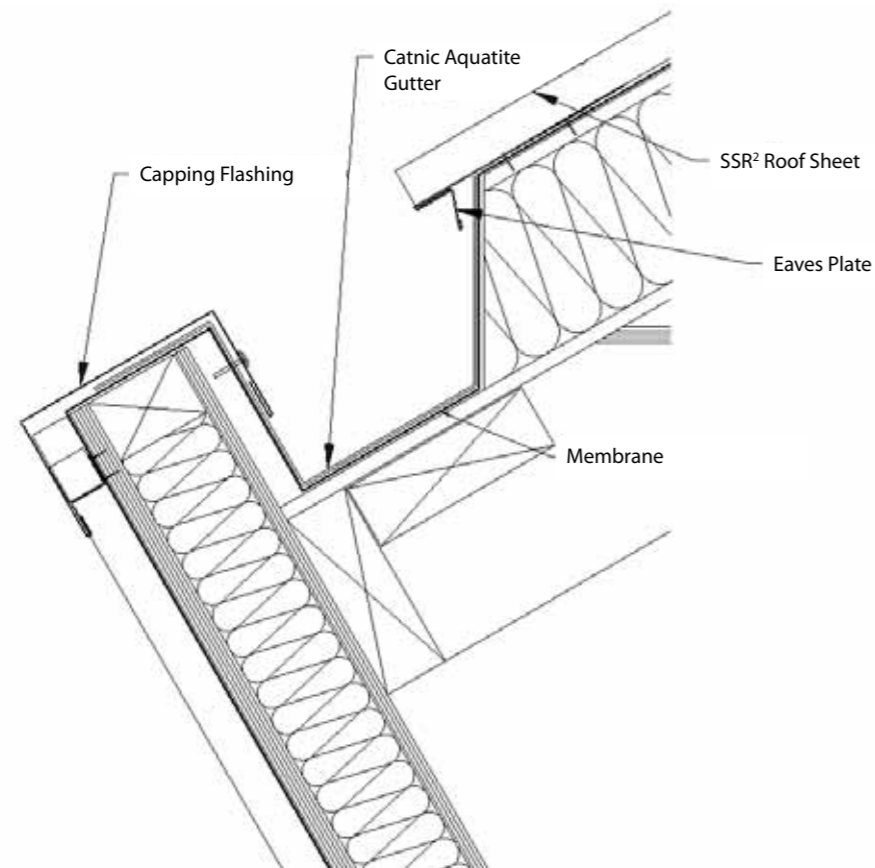

SAFE STORAGE AND HANDLING

All products should be used in accordance with their specific instructions to prevent failure. Please ensure all items ordered are delivered before commencing installation work.

Storage

- Store panels in close proximity to the building where they are to be installed.
- All products should be stored in a clean and dry environment on a firm even surface, clear of the ground on timber bearers spaced no more than 900mm apart.
- If indoor storage is not available cover all sheets with a waterproof covering, which should be supported on a scaffolding frame, leaving sufficient room on all sides for air to circulate.
- Incline the stacks so that any rain water that penetrates the covering will drain off.
- If stacked or bundled products do become wet, then separate and wipe dry with a clean cloth.
- Inspect the sheets at regular intervals to check for any leaks in the covering.

Handling

- Gloves should be worn to avoid injury from any sharp edges.
- When being moved by hand, the panels should be turned and carried on their edge using appropriate personal protective equipment, and where possible, the panels should be lifted manually onto the roof in single sheets.
- The product should be handled in accordance with the Manual Handling Operations Regulations 1992 (as amended version). The panels should be lifted from the stack rather than dragged across it.
- Sheets should be handled carefully to avoid any damage, and where possible only lift single sheets manually onto the roof.
- If sheets have to be hoisted into position ensure edges are protected and that pressure across the sheet does not distort it. Use only ropes and slings for hoisting, never chains.

- Do not drag material over rough surfaces or fixed sheets.
- Bulk sheets should be moved or lifted with a fork-lift truck with appropriate length forks.
- Long sheets should be moved using a lifting beam with suitable slings and spreaders.
- Remove all packaging and wrapping with care and discard safely and responsibly.
- When working on the roof, soft-soled shoes must be worn. The soles should be checked for any sharp objects that could damage the panel or cause injury.

Application

- Do not use damaged goods.
- Alignment and tolerance of the building structure should be carried out prior to installation to ensure it is within the specification given. If not the panels may not fit.
- Do not drag tools over sheets, and protect from swarf.

Cutting

- All panel and fabrication cutting must be completed away from the roof to eliminate the risk of transferring swarf onto the panel.
- All exposed edges should be deburred and protected with touch-up paint.
- For cut-outs, openings and cuts that are not straight use a Jigsaw or reciprocating saw with a fine tooth metal cutting blade.
- We recommend a circular saw producing a 'cold' cut using a fine tooth metal blade for long straight cuts.

Delivery

- The profiled panels are normally delivered to site in pre-specified lengths according to the dimensions of the roof on which they are to be installed and are palletted in packs of 6 or 4 depending on length and weight.
- Delivery is normally by lorry and unloading carried out by crane or moffet. The site must have adequate access and a suitable surface for this traffic.
- During transport, the panels must be suitably restrained to prevent abrasion and their edges and corners protected against damage.

Disposal

- When disposing of any Catnic products or packaging, due consideration must be given to the environmental impact of the method of disposal.

CATNIC SERVICE AND SCHEDULING

Catnic is committed to providing architects, designers and builders with useful information and terminology relevant to the specification of Catnic SSR² Standing Seam Roof and Cladding.

Catnic's sales and technical teams are dedicated to matching the quality of our products with the professional voice at the end of the telephone to our on-site consultation.

The Catnic service package includes:

- Experienced and dedicated team of SSR² sales representatives.
- Fully trained, professional internal customer support team for all your needs; from placing orders, to enquiring about prices or deliveries.
- Comprehensive range of back-up literature.
- On-line help via www.catnic.com.
- CAD details available on-line providing instant access to SSR² drawings.
- Technical enquiry forms to accompany your drawings ensuring necessary information is received and turned around in a timely manner.
- On-site sales and technical support when required.
- Technical hotline for all queries.
- Dedicated hauliers for all your deliveries.
- Consultation at every stage of your job.

Catnic's Technical team can provide:

- A full scheduling service to produce a full take off all over SSR² panels and ancillaries required for a project.
- Comprehensive technical back up on the use and performance of SSR².
- Project specific design advice.
- A wide range of standard details in dwg and pdf format
- Installer training courses
- Product installation guidance documents.



Contact Catnic
Technical Services on

029 2033 7900



SUSTAINABILITY

SSR² standing seam roof and cladding has been developed using eco-design principles, aimed at minimising the environmental impact of the product from raw material production all the way through to re-use or recycling.

Cradle to Cradle

Catnic always ensure its products meet or exceed the performance regulations of current legislation. As part of Tata Steel Europe, we carefully measure the impact of Colorcoat HPS200 Ultra® throughout it's life from cradle to cradle.

The steel used in SSR² is 100% recyclable with zero de-gradation in the materials properties when recycled, unlike nearly all other construction materials.

All paint solvents are recycled through an incineration system to provide heat to the ovens and reduce the amount of natural gas used in the advanced curing process.

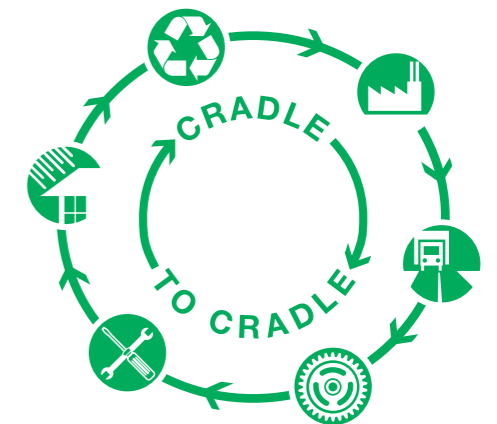

BES 6001

Certification of all our steel construction products to BES 6001 provides independent verification of our corporate responsibility, including the way we drive sustainability considerations across the supply chain to the point of raw material extraction. It delivers a method for us to benchmark and show that we are continuously improving our sustainability credentials.

We have ensured SSR² standing seam roof and cladding has been certified to BES 6001 so you can rest assured that when specifying and installing this sustainable product you will maximise the potential for obtaining credits under the Responsible Sourcing of Materials sections of BREEAM, the Code for Sustainable Homes and CEEQUAL.

Tata Steel are the first steel manufacturer to secure BES 6001 Responsible Sourcing certification, which has been secured for all Colorcoat® pre-finished steel products made in the UK.



BRE Green Guide A+ rated

Manufactured from Colorcoat HPS200 Ultra® by Tata Steel our steel system is BRE Green Guide A+ rated.

Integrated technologies

Developed to assist the designer in meeting the most stringent of future legislative requirements, SSR² standing seam roof and cladding has been designed to allow simple integration of photovoltaic solar thermal and /or passive solar heat collection roof panels.

The system is also compatible with rain water harvesting systems, a design consideration inspiring a versatile range of design considerations that can help towards the delivery of the Code for Sustainable Homes Level 6 target for portable water consumption of 80l/p/d.

ENVIRONMENTAL

Through our research and development, we are continuing to deliver innovative products that provide additional environmental benefits to our customers and society as a whole.

Catnic recognise that in our day-to-day operations across the globe we impact upon the environment in a number of ways. Therefore we are committed to achieving continual improvement in our environmental performance and pollution prevention, in supporting government policy for sustainable development.

ISO 14001

Since 2010 Catnic has held the Environmental Management Standard ISO 14001 in recognition of its environmental management policy. Our products are durable, adaptable, reusable and recyclable. All manufacturing processes are carefully controlled to the highest environmental standards.



Eco-design

SSR² standing seam roof and cladding has been developed using raw materials with a lower environmental impact than detailed by current legislative standards. Heavy metals and unnecessary fire retardants have been eliminated from the topcoat, and high performing alternatives to undesirable organotin stabilisers and phthalate plasticisers have been introduced.

Ozone Depletion Potential (ODP)

Catnic SSR² standing seam roof and cladding confirms to the Montreal Protocol and has zero ozone depletion potential.

Catnic has:

- Integrated environmental management into all our business activities
- Ensured compliance with all relevant local, national and international legislation and regulations
- Ensured all staff, including contractors, actively support our environmental programmes
- Communicated our environmental policy clearer to all internal and external parties, responding appropriately to requests for information

We seek to reduce our environmental impact and improve sustainability through continuous improvements in:

- Energy efficiency and water consumption
- Waste management and in particular a reduction in the amount of waste we send to landfill
- Contract management and purchasing

Our policy is renewed and reviewed annually, and forms the basis of all future environmental improvements. Copies of our latest environmental policy are available for download today at catnic.com/downloads



SSR² CASE STUDIES

Project: Little Owls Nursery

Location: Armendale, West Lothian – Scotland

Architect: 99 Design Architects

Built by: Balgownie Scotland Ltd

Roofing Contractor: McDonald Roofing

Overview

Originally designed with an aluminium roof, Little Owls Nursery changed specification to the more cost effective solution of Catnic's SSR² standing seam roof. Initially chosen for its aesthetic appeal and performance quality, the modern installation efficiencies afforded by SSR² soon demonstrated further savings during the installation.

"The use of any new product brings an exciting challenge, however the SSR² system has proven easy to install to our team of specialist roofers. Each section features an integrated eyelet hole fixing strip – so once all the flashings are fixed you simply slot the roofing sections into place. From McDonald Roofing's perspective it's great – the SSR² product can ensure the building is watertight and secure as quickly as possible."

Stewart McDonald, Director of McDonald Roofing

